

# MODEL: V-068B

Wafer Swing Check Valve PN16 & ANSI CLASS150/300

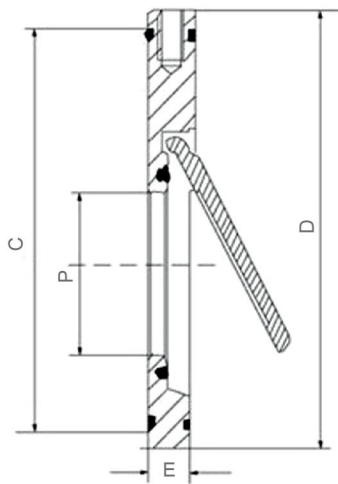

## Specification : API-6D Design

This valve is highly appreciated for its method way of mounting (between flanges) space saving and its light weight, which also makes its price very competitive. The large range of materials allwits instal lation in a large scope of applications from the common ones (clear water, general water applications) to the most sophisticated in indus trial process.

## Features

Wafer swing check valve is for a special proposal not to be asked fully opening. As see, it is lighter, smaller and therefore less expense to install and maintain than conventional check valves. Also without spring design give a very less opening pressure.

## Material

No.	Part Name	Material
1	Body	SS316
2	Disc	SS316
3	Seat Ring	VITON(Option: PTFE/SS316)
4	Flange Ring	VITON(Option: PTFE/SS316)

Norminal Pressure	PN16	CL150 (PN20)	CL300 (PN50)
Seal Test Pressure (BARg)	17.6	22	55
Body Test Pressure (BARg)	24	30	75

Characteristics	Seat Material	V-068BV	V-068BT	V-068BS
		Viton	PTFE	SS316
Temperature in °C	Min.	-20	-20	-268
	Max.	150	180	538
Pressure in bar	Service	16 (PN16)		
	Testing Pressure	25 (PN16)		
Medium	Water, oil, gas, steam, sea water, air, fuel, hydrocarbons, thick and viscous liquids			

## Dimensions

mm

DN	D				P	E		
	PN16	Table D	ANSI 125/150	ANSI 300		PN16	ANSI 150	ANSI 300
40	92	85	85	95	22	14	19	19
50	109	98	105	111	32	14	19	19
65	129	111	124	130	40	14	19	19
80	144	130	136	149	54	14	19	19
100	164	162	175	181	70	18	19	19
125	194	194	197	216	92	18	19	19
150	220	219	222	251	114	20	19	22
200	275	276	279	308	154	22	28	28
250	330	337	340	362	200	26	28	38
300	380	387	410	422	235	28	38	51
350	440	448	451	485	280	38	44	51
400	491	499	515	540	316	44	51	51